

Innocard

Minerva

GDC36-9201

Mini SAS HD (SFF-8673) PCIe 4.0 to U.2 (SFF-8639) Cable

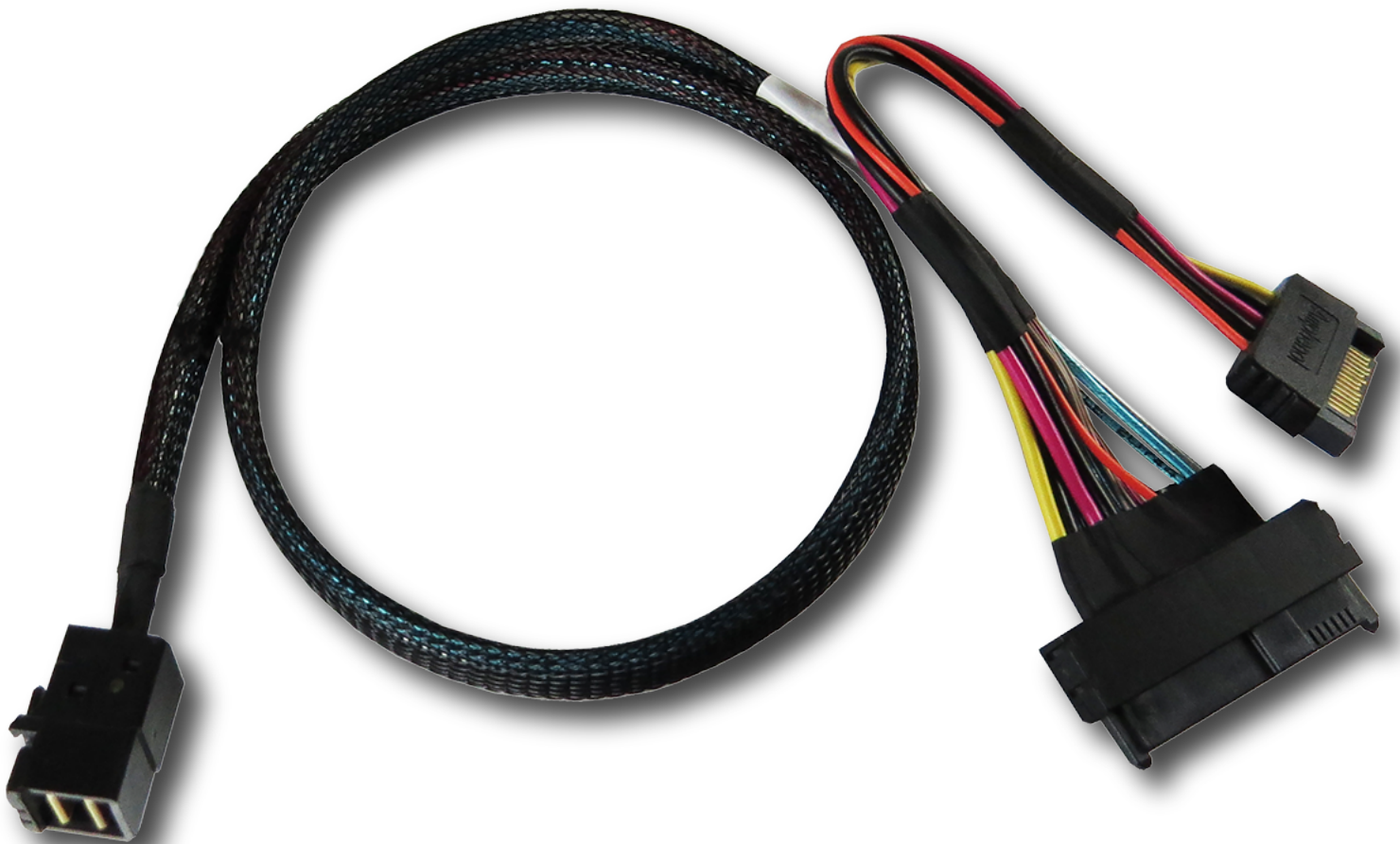

Mini SAS HD (SFF-8673) PCIe 4.0 to U.2 (SFF-8639) Cable, 50cm

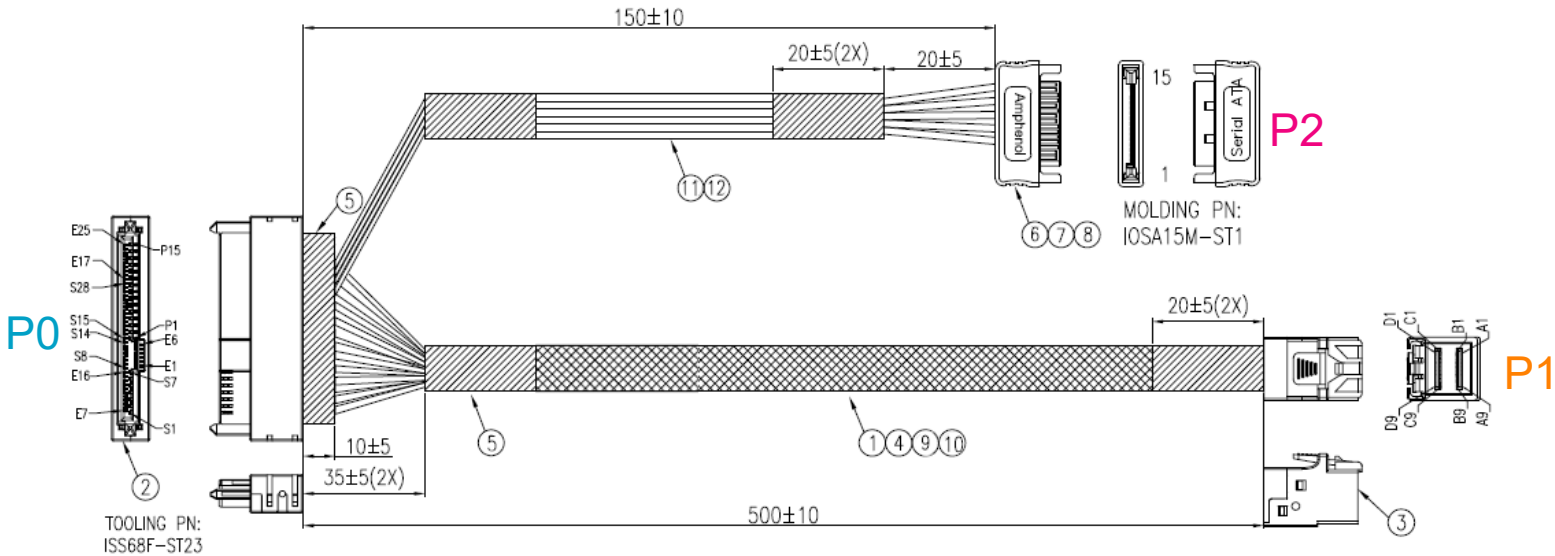
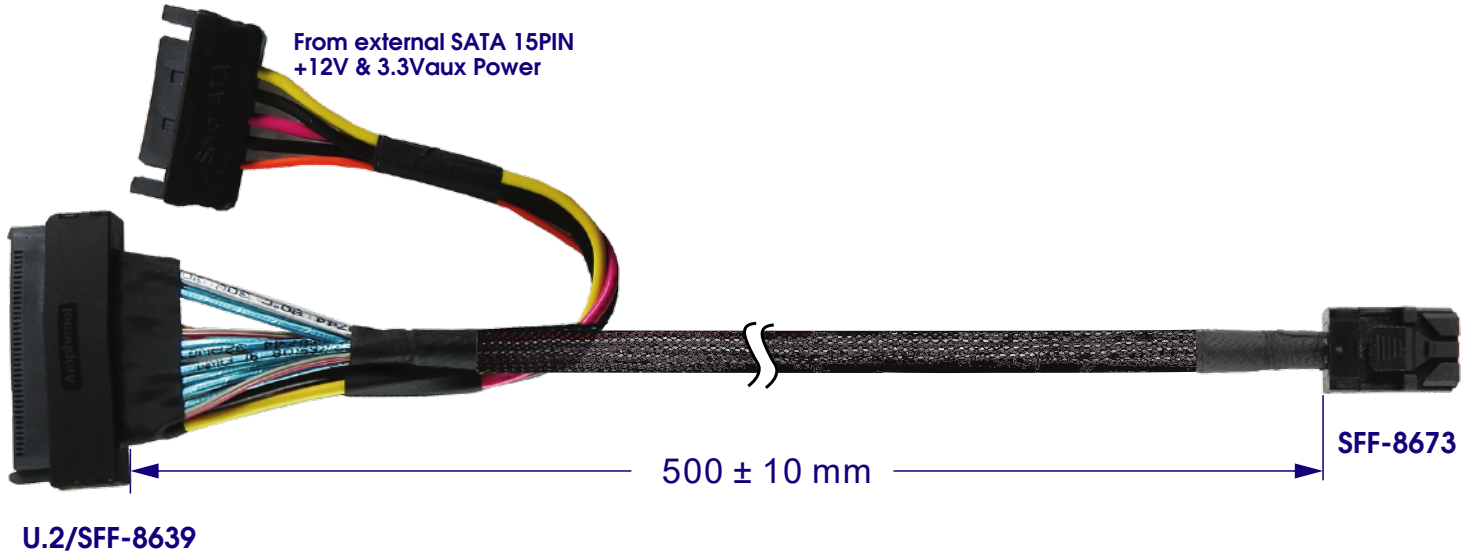

12	R1007024XX	WIRE,24AWG,UL1007,R2	A/R
11	R1007018XX	WIRE,18AWG,UL1007,R2	A/R
10	HWSS300036	SAS CBL:UL20744.30#1P+2D.VW-1,100ohm,NATURAL,HF	A/R
9	H0330230CX	WIRE,.30AWG,UL3302,NO MARKING,HF	A/R
8	RMRPV45092	RESIN:PVC,45P,VO,BLK,W/O TOTM,R2	A/R
7	HMRPE45NT1	PE:LOW DENSITY,CLEAR,HF	A/R
6	(H)10115M03	SATA CONN:15P,M,GOLD PLATED,VO,BLK	1
5	HMMTP0XXXX	TAPE,BLK,HF	A/R
4	HMTB00XXXX	EXPANDO TUBE,BLACK,HF	A/R
3	AST8643-0036-04	HD MINI SAS 4X STR SHORT TYPE	1
2	AST8639-0020	SFF8639 STR PLUG Gen5 no PCB	1
1	HWSS320006	SAS CBL:UL20744.32#2C+2D+AM+HM,BLU,850,VW-1,12G,HF	A/R
ITEM	VENDOR P/N	DESCRIPTION	QTY

Mini SAS HD (SFF-8673) PCIe 4.0 to U.2 (SFF-8639) Cable, 50cm

Wire Table

P0	E3	P1	P2	P3	P4	P5	P6	P7	P8	P9	P10	P11	P12	P13	P14	P15	
P2	P1.P2.P3	— — — —				P4 P5 P6	P7	P8	P9	P10	P11	P12	P13	P14	P15		
SYMBOL	3.3V	— — — —				GND	5V			GND			12V				
WIRE AWG	24AWG	— — — —				18AWG	18AWG			18AWG			18AWG				
WIRE COLOR	ORG	— — — —				BLACK	RED			BLACK			YELLOW				

Pin-out assignment

P0/SFF-8639

P1/SFF-8673

